

Singly separable version

DIX MDW 2 - 300

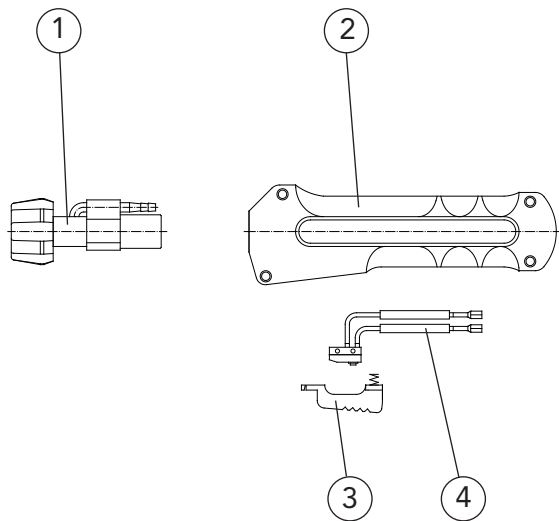

Pos. Description

Part number

Article number

- 1 Torch connection
- 2 Handle
- 3 Trigger
- 4 Microswitch

- DIX 15 - 2 DW
- DIX 7 - 2 - 303 D
- DIX 9 - 2
- DIX 8 - 2

- 629 150 470
- 629 070 340
- 629 090 000
- 629 080 000

subject to change!

ELGB-MDW2-300\K03

