

Standard fittings

MANUAL WELDING TORCHES

gas cooled

MIG/MAG



DINSE

Torch sets

1 - 230

Torch type

DIX MS 1 - 230

DIX MG 1 - 230

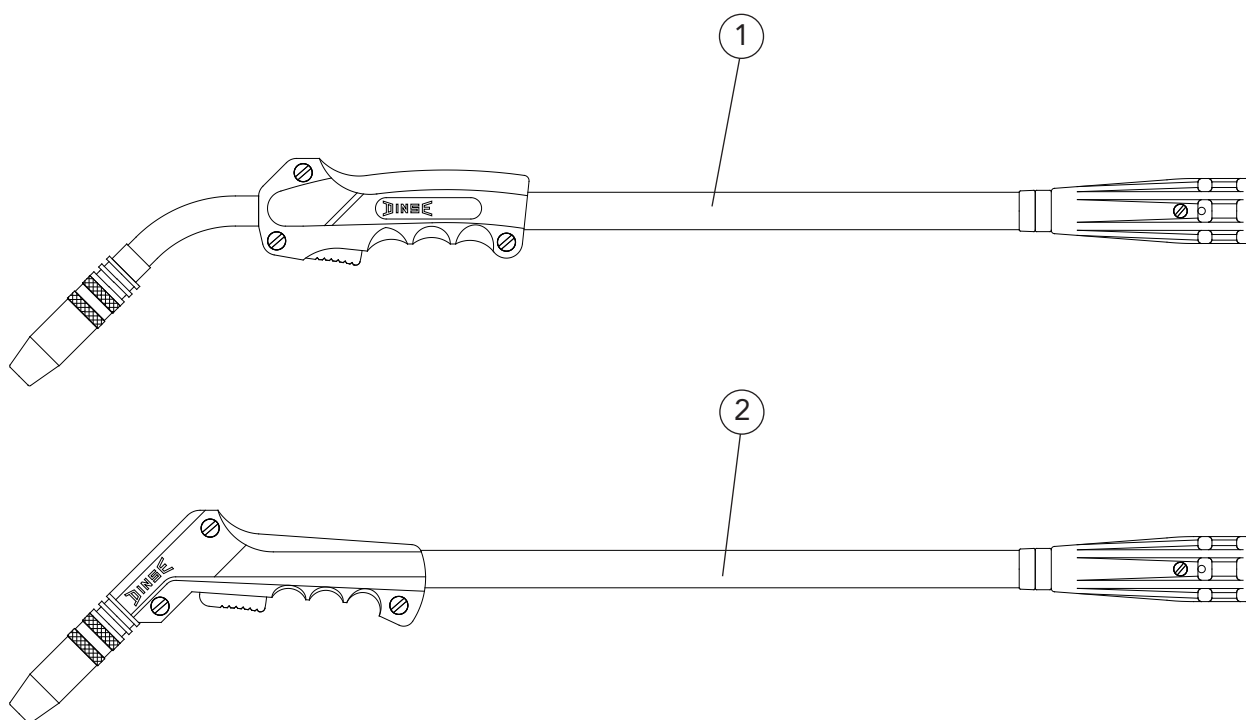

subject to change!

SEGB-MS-MG1-230\K03

Pos.	Description	Dimension	Part number	Article number
1	Torch set	45° 3,00 m	DIX MS 1 - 230 - 3	610 012 313 0
	Torch set	45° 4,00 m	DIX MS 1 - 230 - 4	610 012 314 0
2	Torch set	45° 3,00 m	DIX MG1 - 230 - 3	610 002 313 0
	Torch set	45° 4,00 m	DIX MG1 - 230 - 4	610 002 314 0

► Standard equipment for wire diameter 1,0 mm steel with gas nozzle diameter 13 mm, DIX 1-1-312 TR, (contact tip DIX 3-1-1,0, set back, tip adapter DIX 4-1-L, liner DIX DS 4/1,8). Variants deviating of the standard fittings on request.

